

SPECIFICATION

SPEC. NO. : _____ REV : XB

DATE : Jul-18-2001

PRODUCT NAME : RJ-45 1 Row X 1 Port With Transformer
Module

PRODUCT NO : P02-102-17C9

宣 得 股 份 有 限 公 司

SPEED TECH CORP.

桃園縣龜山鄉民生北路一段 568 號
NO. 568, SEC. 1, MING-SHENG N. ROAD.,
KWEI-SHAN HSIANG, TAOYUAN HSIEN,
TAIWAN, R.O.C.
TEL : 886-3-2120088
FAX : 886-3-2121781

	APPROVED	CHECKED	PREPARED
NAME			

Product Number : P02-102-17C9

Product Description : RJ-45 1 Row X 1 Port With Transformer Module Product Number : P02-102-17C9

1 SCOPE

1.1 Content

1.1.1 This specification covers performance, tests and quality requirements for RJ-45 1 Row X 1 Port With Transformer Module.

2 APPLICABLE DOCUMENTS

The following documents form a part of this specification to the extent specified herein. Unless otherwise specified, latest edition of the specification applies. In the event of conflict between requirements of this specification and product drawing, product drawing shall take precedence.

2.1 Commercial standards, specifications and report

2.1.1 MIL-STD-1344A

2.1.2 MIL-STD-202F

3 MECHANIC DIMENSIONS

3.1 Dimensions

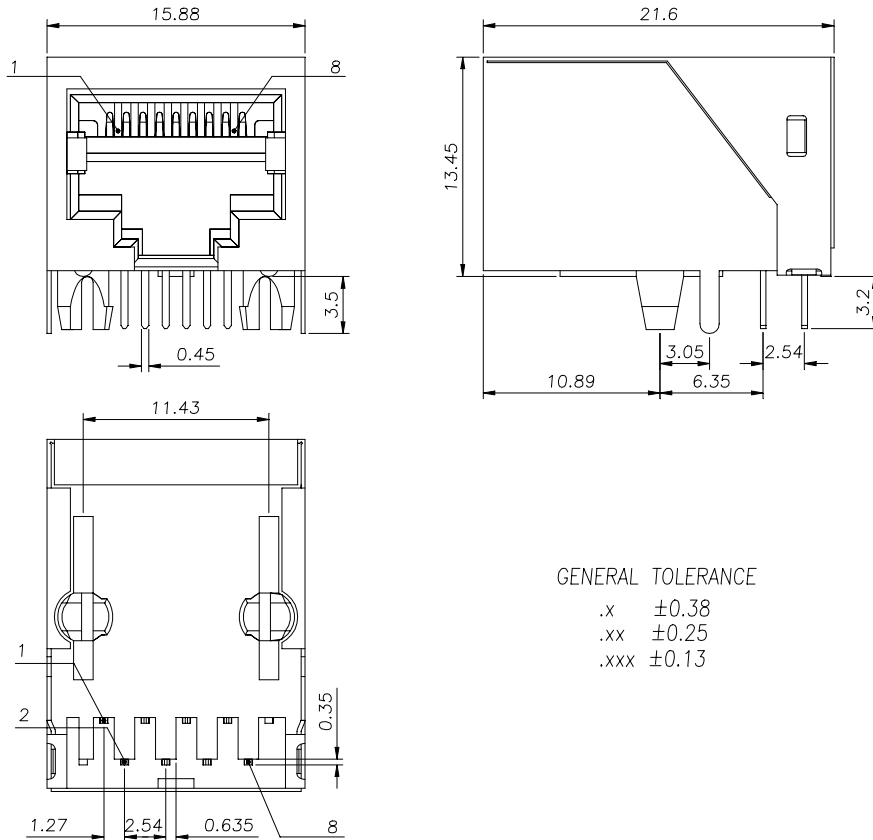

3.2 PCB Layout

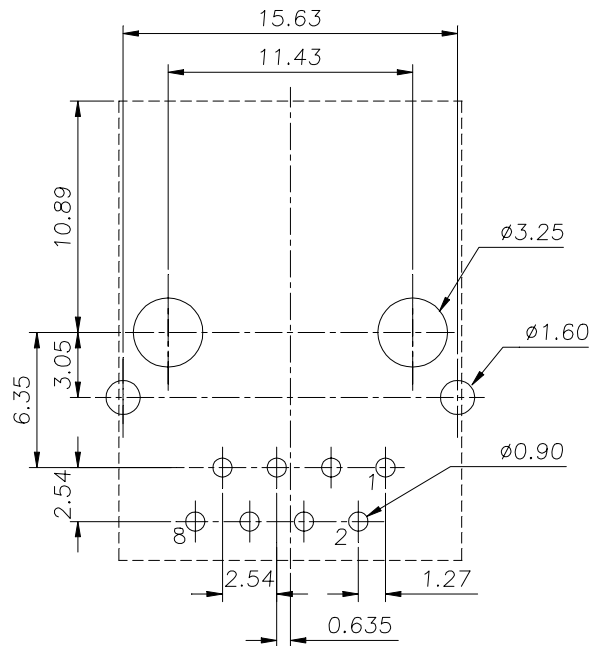

RECOMMENDED P.C.B. LAYOUT
(COMPONENT SIDE)

4 REQUIREMENTS

4.1 Design and Construction

4.1.1 Product shall be of design, construction and physical dimensions specified on applicable product drawing.

4.2 Materials and Finish

4.2.1 Contact :

4.2.1.1 RJ Upper Contact : Phosphor Bronze , Thickness=0.35mm

Finish : (a) Contact Area : 30μ " min. Gold

(b) Solder tail Area : 100μ " min. Tin/Lead (9:1)

(c) Underplating : 50μ " min. Nickel over all

4.2.1.2 RJ Lower Contact : Phosphor Bronze , Thickness=0.35mm

Finish : (a) Contact Area : 100μ " min. Tin/Lead (9:1)

(b) Solder tail Area : 100μ " min. Tin/Lead (9:1)

(c) Underplating : 50μ " min. Nickel over all

4.2.2 Plastic Part :

4.2.2.1 RJ Housing : Thermoplastic , NYLON 6T , Black

UL FILE No. : E52579(M)

Manufacturer : MITSUI Petrochemical Industries

Grade : CH230N

Flame Class : UL 94V-0

4.2.2.2 Insert : Thermoplastic , NYLON 6T , Black

UL FILE No. : E52579(M)

Manufacturer : MITSUI Petrochemical Industries

Grade : CH230N

Flame Class : UL 94V-0

4.2.3 Shell :

4.2.3.1 Front Shell : Stainless, SUS 304 , Thickness=0.25mm

4.2.3.2 Back Shell : Stainless, SUS 304 , Thickness=0.20mm

4.2.4 Transformer :

4.2.4.1 Material : FR4 , Thickness=1.0mm

4.2.4.2 Two Layer PCB

4.3 Operating and Storage Temperature

4.3.1 Operating Temperature : 0°C TO 85°C

4.3.2 Non-Operating Temperature : -40°C TO 75°C

4.4 Ratings

4.4.1 Voltage rating : 125 VAC

4.4.2 Current rating : 1.5 A

4.5 Performance and Test Description

Product is designed to meet electrical, mechanical and environmental performance requirements specified in below table. All tests are performed at ambient environmental conditions per MIL-STD-1344A unless otherwise specified.

4.6 Packaging and Packing

All parts shall be packaged and packed to protect against physical damage, corrosion and deterioration during shipment and storage.

5 ELECTRICAL CHARACTERISTICS

5.1 Schematic

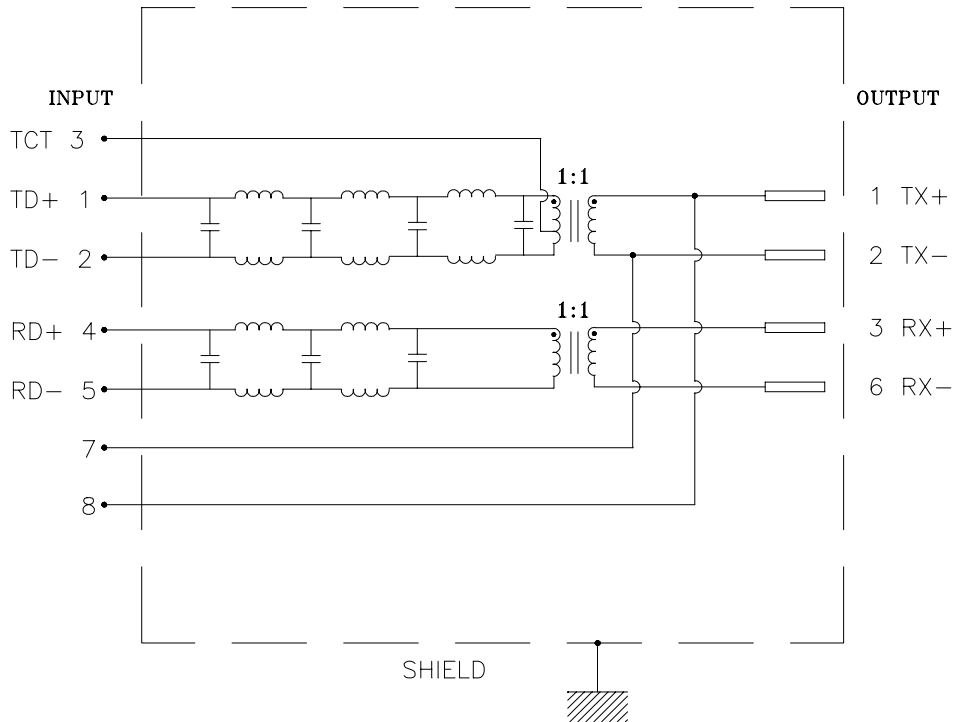

5.2 Transmitter filter

Type : Balance low pass 100 OHM impedance

Cut off frequency : 17 ± 1.5 MHz -3.0 dB TYP

Insertion loss : 1-10 MHz -1.0 dB MAX.

Attenuation : @ 30 MHz -32 dB MIN.

@ 50 MHz -35 dB MIN.

Return loss : 1-10 MHz -18 dB MIN. load 100 OHM

5.3 Receiver filter

Type : Balance low pass 100 OHM impedance

Cut off frequency : 17 ± 1.5 MHz -3.0 dB TYP

Insertion loss : 1-10 MHz -1.0 dB MAX.

Attenuation : @ 30 MHz -20 dB MIN.

@ 50 MHz -25 dB MIN.

Return loss : 1-10 MHz -18 dB MIN. load 100 OHM

5.4 Common Mode Rejection

@ 1-50 MHz -30 dB MIN.

@ 50-100 MHz -25 dB MIN.

5.5 Cross Talk

@ 1-10 MHz -35 dB MIN.

5.6 HiPot TEST

Input(1-2) to Output(1-2) : 1500VAC, 60sec

Input(4-5) to Output(3-6) : 1500VAC, 60sec

6 ORDER INFORMATION :

PXX - 1 XX - X XX X
A B C D E

A : Number Ports

02. RJ-45 1 Row X 1 Port With Transformer Module

B : Shield Type

02. B Type

C : Solder

1. Through Hole

D : Type of Circuit

7C. 7C Type Circuit

E : Contact Plating

Selected Gold Plating

9. 30u" minimum Gold on Contact Area

7 Test Requirements and Procedures Summary

7.1 Test Requirements

Test Description	Requirement	Procedure
Confirmation of Product	Product shall be conforming to the requirements of applicable product drawing and application specification.	Visual, dimensional and functional per applicable quality inspection plan.
Low Level Contact Resistance	100 mΩ maximum initial ΔR = 50 mΩ maximum final	Subject mated contacts assembled in housing to closed circuit current of 10mA maximum at open circuit voltage of 20mV maximum obtain resistance value by dividing the measured reading in to two, as show figure 1. In accordance with test method 3002.1 of MIL-STD-1344A.
Dielectric strength	No creeping discharge nor flashover shall occur. Current leakage : 0.5mA maximum.	1000VAC for 1 minute test between adjacent circuits of mated/unmated connectors, in accordance with test method 3003.1 of MIL-STD-1344A.
Insulation resistance	100 MΩ minimum	Impressed voltage 100VDC. test between adjacent circuits of mated/unmated connectors in accordance with test condition "A", test method 3003.1 of MIL-STD-1344A.
Vibration	No electrical discontinuity greater than 1 μ second shall occur.	Fix the mated connectors on the vibrating plate, after having all the contacts series-wired and energized with test current of 100mA flowing through the circuit. Test in accordance with test method 2005.1 of MIL-STD-1344A, by applying vibration of the following : sweeping frequency : 10-50Hz to reciprocate one cycle every 1 minute Amplitude : 1.52mm Direction : X , Y&Z axes. Duration : 2 hours each.
SPEC NO.:	REV. : XB	ECN NO. :
PAGE : 6 / 8		

Mechanical shock	No electrical discontinuity greater than 1 μ second shall occur.	With all the contacts series-wired and connectors mated, apply the test current of 100mA to the test circuit, test by dropping the connectors in accordance with condition A, test method 2004.1 of MIL-STD-1344A. The physical shock intensity to be : 50G maximum (490m/S) to from half sine wave during 11ms. Number of drops : X , Y&Z axes each 6 drops, totally 18 drops.
Durability (Repeated mating / unmating)	$\Delta R = 30 \text{ m}\Omega$ maximum final	Repeat insertion and extraction of PCB to and from the connector with the turns to lock it and then unlock it for 500 cycles.
Solderability	Wet solder coverage : 95% minimum.	After immersing test area into flux for 5~10 second, immerse into soldering tub controlled at $230 \pm 5^\circ\text{C}$ for 3 ± 0.5 second.
Thermal shock	$\Delta R = 50 \text{ m}\Omega$ maximum final No physical abnormalities shall be present after the test.	Expose mated pair of connectors under the temperature changes between -55°C and 85°C for 5 cycles holding for 30 minutes at the both extremes, in accordance with condition A, test method 107 of MIL-STD-202F.
Humidity temperature cycling	No physical abnormalities shall be present after the test. Low level contact resistance : $\Delta R = 50 \text{ m}\Omega$ maximum final	Mated connector shall be subject to the test condition in accordance with test method 106E of MIL-STD-202F, except step 7b.
SPEC NO.:	REV. : XB	ECN NO. : PAGE : 7 / 8

7.2 Product Qualification and Test Sequence

Test Items	Test Group					
	1	2	3	4	5	6
	Test Sequence					
Confirmation of Product	1,7	1,5	1,5	1,6	1,5	1,5
Low Level Contact Resistance		2,4	2,4	2,4	2,4	2,4
Dielectric Strength	3,6					
Insulation Resistance	2,5					
Vibration(Frequency)		3				
Mechanical Shock			3			
Durability (Repeated mating / unmating)				3		
Solderability				5		
Thermal Shock					3	
Humidity Temperature Cycling	4					3

(a) Number indicate sequence in which test are performed.

(b) Discontinuities shall not take place in the group 2 & group 3 during test.

Figure 1